

ELECTRONIC SCALE

Line: Electronic Scale
Brand: TORREY
Model: PC40L-HS, PC80L-HS
Page 1-19

FROM THE SERIAL NUMBER: B19-000001 (PC40L-HS)
B19-000001 (PC80L-HS)

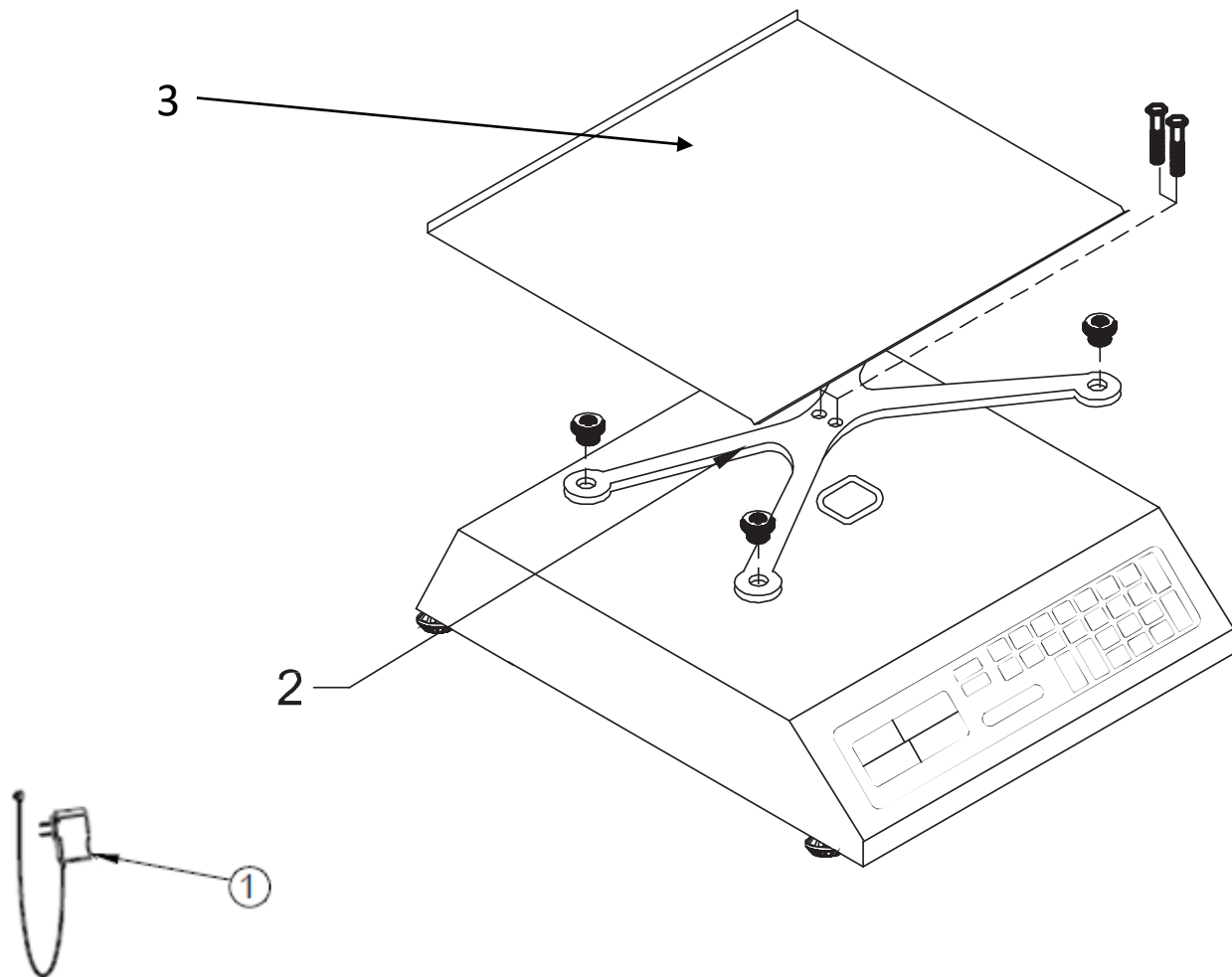



ELECTRONIC SCALE

Line: Electronic Scale

Brand: TORREY

Model: PC40L-HS, PC80L-HS

Page 1-19

No.	Description.	Code
01	110V/220V 6Vcc 500mA SPT POWER SUPPLY	B-21900978
02	ASSEMBLY MFQ N PLATE HOLDER	B-36700114
03	C.20 PCR20 PLATE W/BOLTS	B-56300257

ELECTRONIC SCALE

Line: Electronic Scale
Brand: TORREY
Model: PC40L-HS, PC80L-HS
Page 2-19

FROM THE SERIAL NUMBER: B19-000001 (PC40L-HS)
B19-000001 (PC80L-HS)

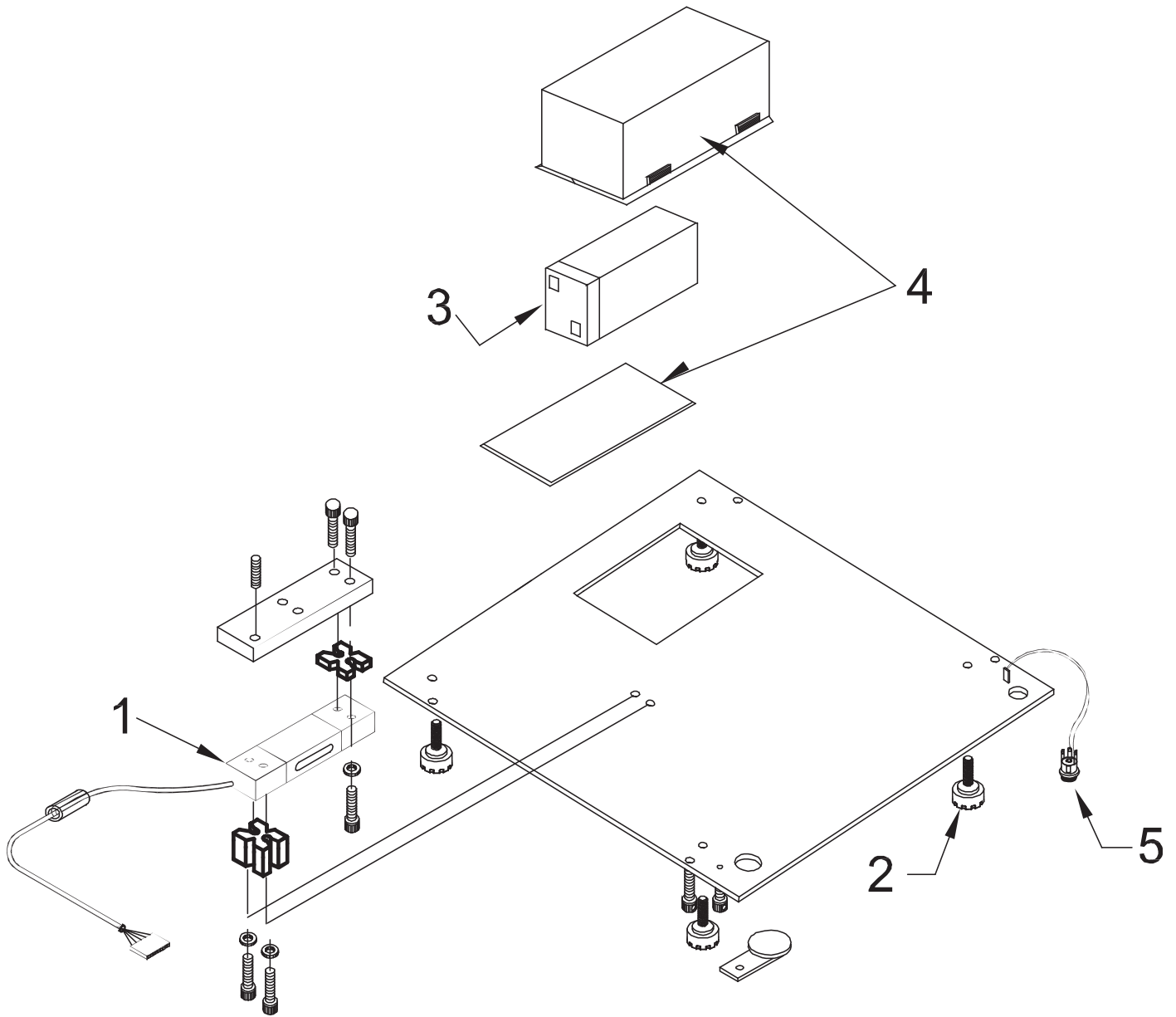

ELECTRONIC SCALE

Line: Electronic Scale

Brand: TORREY

Model: PC40L-HS, PC80L-HS

Page 2-19

No.	Description.	Code
01	20KG LOAD CELL M022 USA NO POL ASSEMBLED	B-46600964
02	CIRCULAR LEVELING BASE PCR	B-22400041
03	4V 2.5 AH RECHARGEABLE BATTERY	B-21900926
04	SNAP BOX KIT	B-22400042
05	JACK 38 CM NO POL ASSEMBLED	B-46600717

FOR THE PC80L-HS MODEL:

No.	Description.	Code
01	40KG LOAD CELL FERRITE ASSEMBLED	B-46600695
05	THREADED JACK LPCR40 ASSEMBLED	B-46601093

ELECTRONIC SCALE

Line: Electronic Scale
Brand: TORREY
Model: PC40L-HS, PC80L-HS
Page 3-19

FROM THE SERIAL NUMBER: B19-000001 (PC40L-HS)
B19-000001 (PC80L-HS)

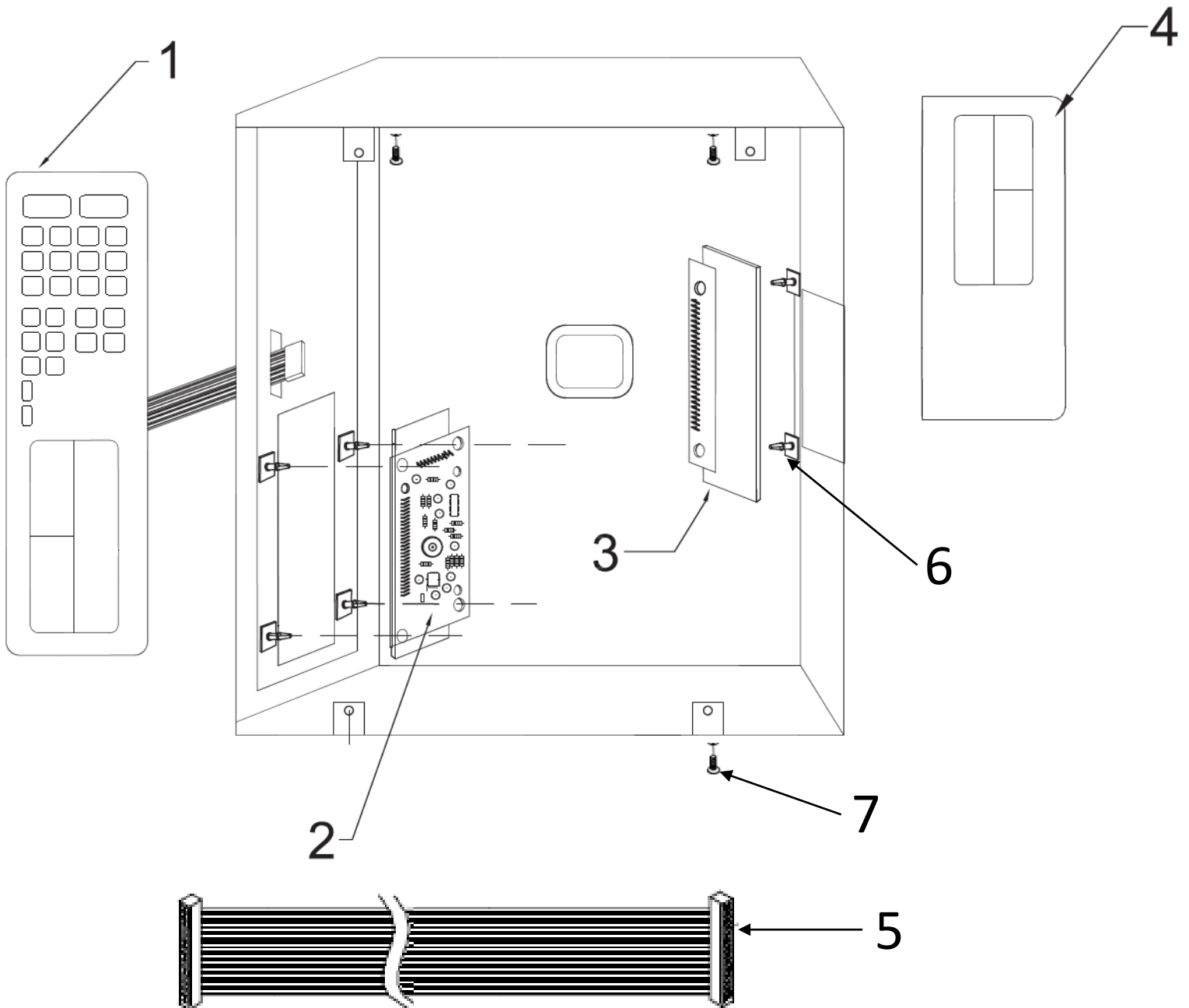

ELECTRONIC SCALE

Line: Electronic Scale

Brand: TORREY

Model: PC40L-HS, PC80L-HS

Page 3-19

No.	Description.	Code
01	KEYBOARD PC 40L CAPACITIVE R1	B-20200612
02	TM TMPPTCAPIMP (PC-HS) ENS	B-46601449
03	TDPPTR5 LCD W/BAT (113.3mm x 49.4MM) ASSEMBLED	B-46601388
04	OVERLAY REAR DISPLAY PC 40L R0	B-23300566
05	PLANE CABLE HARNESS PCR (21in)	B-21900472
06	SUJSEP TARJ. PCR #MS8 (3M) PINGOOD	B-12400118
07	SCREW. 8-32x 1/2 C/RED PHILLIPS GALV	B-12100385
08	RS232/DB9 CABLE	B-21900444

FOR THE PC80L-HS MODEL:

No.	Description.	Code
01	KEYBOARD PC80L CAPACITIVE R1	B-20200614
04	OVERLAY REAR DISPLAY PC 80L R0	B-23300567