

PORTIONING SCALE

Line: Electronic Scale
Brand: TORREY
Model: PZC5-USA, PZC10-USA
Page 1-15

FROM THE SERIAL NUMBER: J15-XXXXXX (PZC5-USA)
J15-XXXXXX (PZC10-USA)

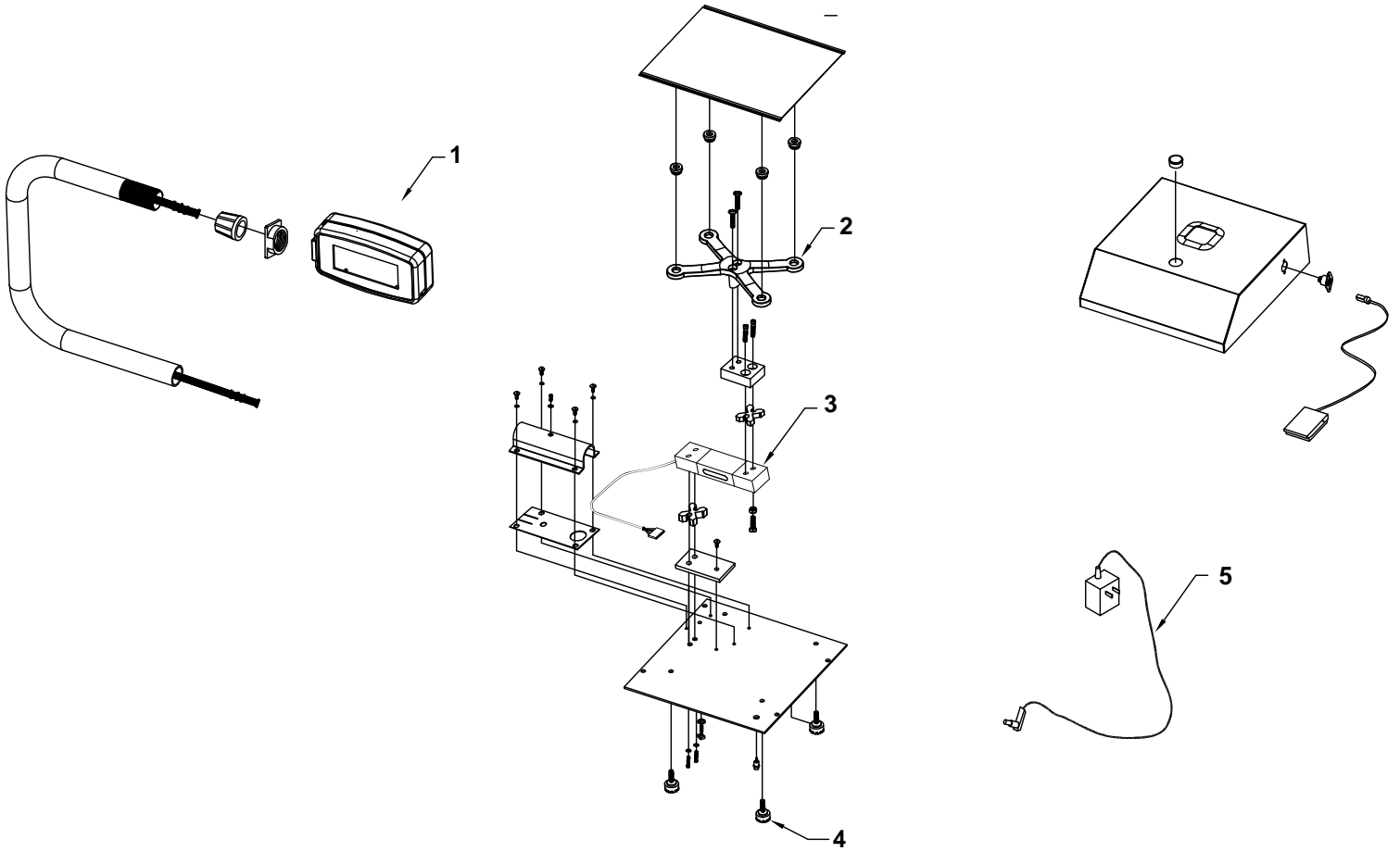



PORTIONING SCALE

Line: Electronic Scale

Brand: TORREY

Model: PZC5-USA, PZC10-USA

Page 1-15

No.	Description.	Code
Ø1	MODULE	VIEW PAG.2
Ø2	PLASTIC PLAT HOLDER ASSEMBLED*	34700041
Ø3	LOAD CELL PZC5 (TSA2) ASSEMBLED	46601048
Ø4	ROUND PCR LEVELING FEET	22400041
Ø5	ELIM. BAT. 110/220V 9Vcc 500 mA SPT	21900706

***FOR MODEL PZC10-USA**

No.	Description.	Code
Ø3	LOAD CELL PZC10 (TSA2) ASSEMBLED	46601047

PORTIONING SCALE

Line: Electronic Scale
Brand: TORREY
Model: PZC5-USA, PZC10-USA
Page 1-18

FROM THE SERIAL NUMBER: A18-XXXXXX (PZC5-USA)
A18-XXXXXX (PZC10-USA)

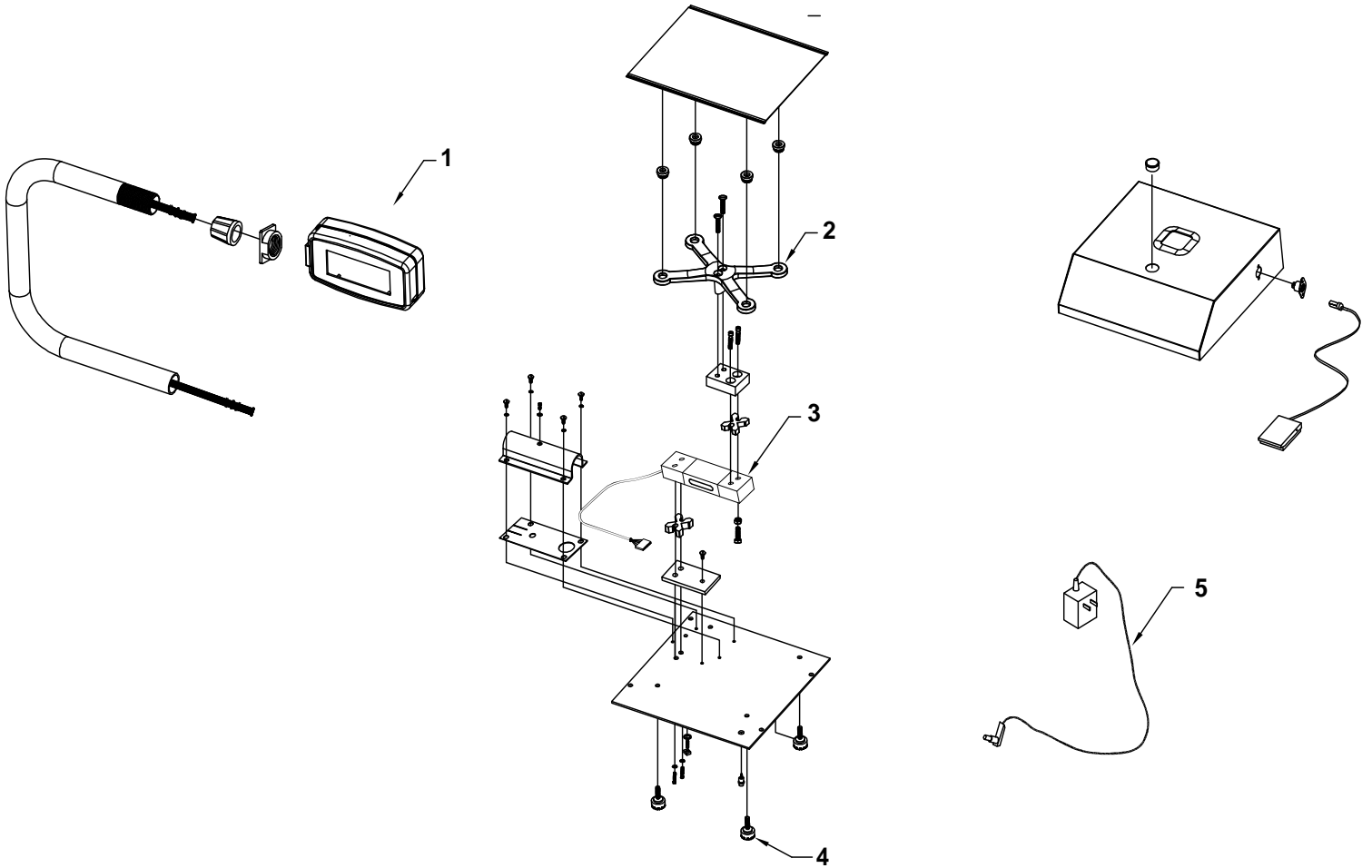



PORTIONING SCALE

Line: Electronic Scale

Brand: TORREY

Model: PZC5-USA, PZC10-USA

Page 1-18

No.	Description.	Code
Ø1	MODULE	VIEW PAG.2
Ø2	PLASTIC PLAT HOLDER ASSEMBLED	34700041
Ø3	LOAD CELL PZC5 (TSA2) ASSEMBLED	46601048
Ø4	ROUND PCR LEVELING FEET	22400041
Ø5	ELIM. BAT. 110/220V 9Vcc 500 mA SPT	21900706

*FOR MODEL PZC10-USA

No.	Description.	Code
Ø3	LOAD CELL PZC10 (TSA2) ASSEMBLED	46601047

PORTIONING SCALE

Line: Electronic Scale
 Brand: TORREY
 Model: PZC5-USA, PZC10-USA
 Page 2-15

FROM THE SERIAL NUMBER: J15-XXXXXX (PZC5-USA)
 J15-XXXXXX (PZC10-USA)

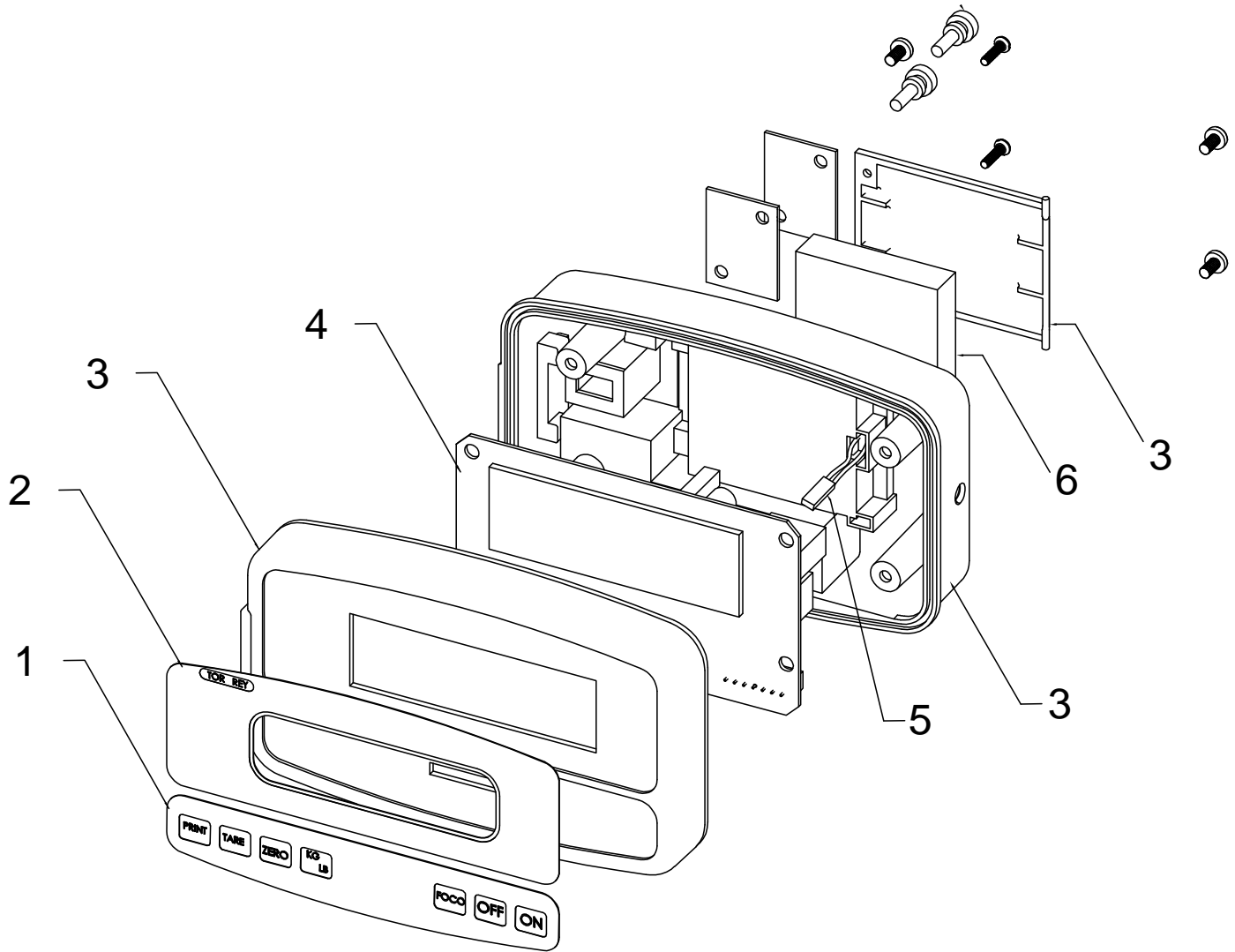



PORTIONING SCALE

Line: Electronic Scale

Brand: TORREY

Model: PZC5-USA, PZC10-USA

Page 2-15

No.	Description.	Code
01	KEYBOARD PZC-5 3D	20200520
02	OVERLAY PZAC WITH MODULE WI	23300274
03	KIT MODULE WI (CASE)	36700345
04	MASTER BOARD PZC WITH TMWISTRØ ASSEMBLED	46601113
05	HARNESS FOR BATTERY WI MH ASSEMBLED	46601073
06	BATTERY 6V 900 (mAh) NiMH ENS.	46601077

PORTIONING SCALE

Line: Electronic Scale
Brand: TORREY
Model: PZC5-USA, PZC10-USA
Page 2-18

FROM THE SERIAL NUMBER: A18-XXXXXX (PZC5-USA)
A18-XXXXXX (PZC10-USA)

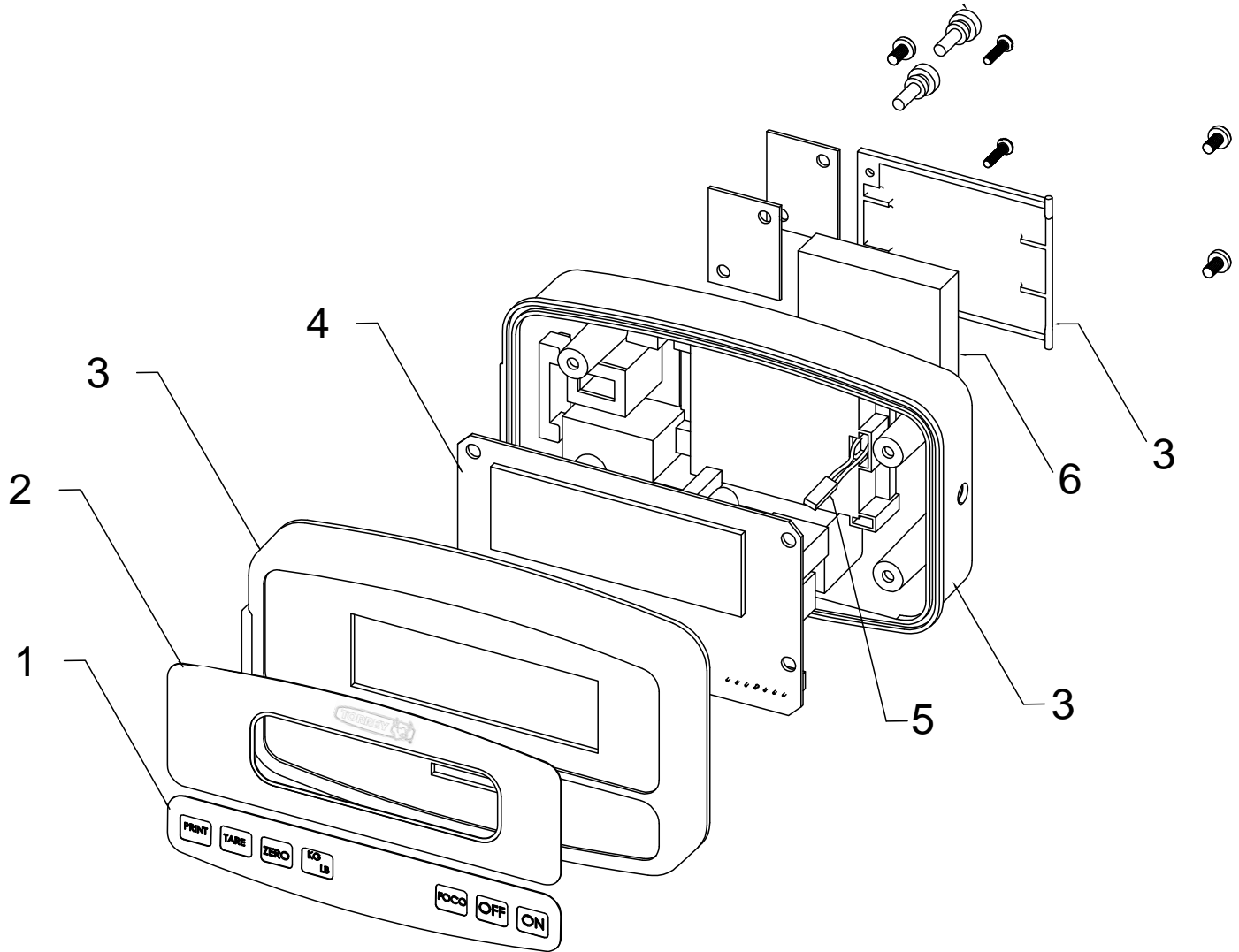



PORTIONING SCALE

Line: Electronic Scale

Brand: TORREY

Model: PZC5-USA, PZC10-USA

Page 2-18

No.	Description.	Code
01	KEYBOARD PZC-5 3D	20200520
02	OVERLAY INDICATOR MODULE NL R0	23300524
03	KIT MODULE WI (CASE)	36700345
04	MASTER BOARD PZC TMWISTR5 ASSEMBLED	46601295
05	HARNESS FOR BATTERY WI MH ASSEMBLED	46601073
06	BATTERY 6V 900 (mAh) NiMH ENS.	46601077