

COMERCIAL SCALE

Line: Electronic Scale

Brand: TORREY

Model: PC40LT / PC80LT

Page 1-13

FROM THE SERIAL NUMBER: F10-000001 (PC40 LT)
D11-000001 (PC80 LT)

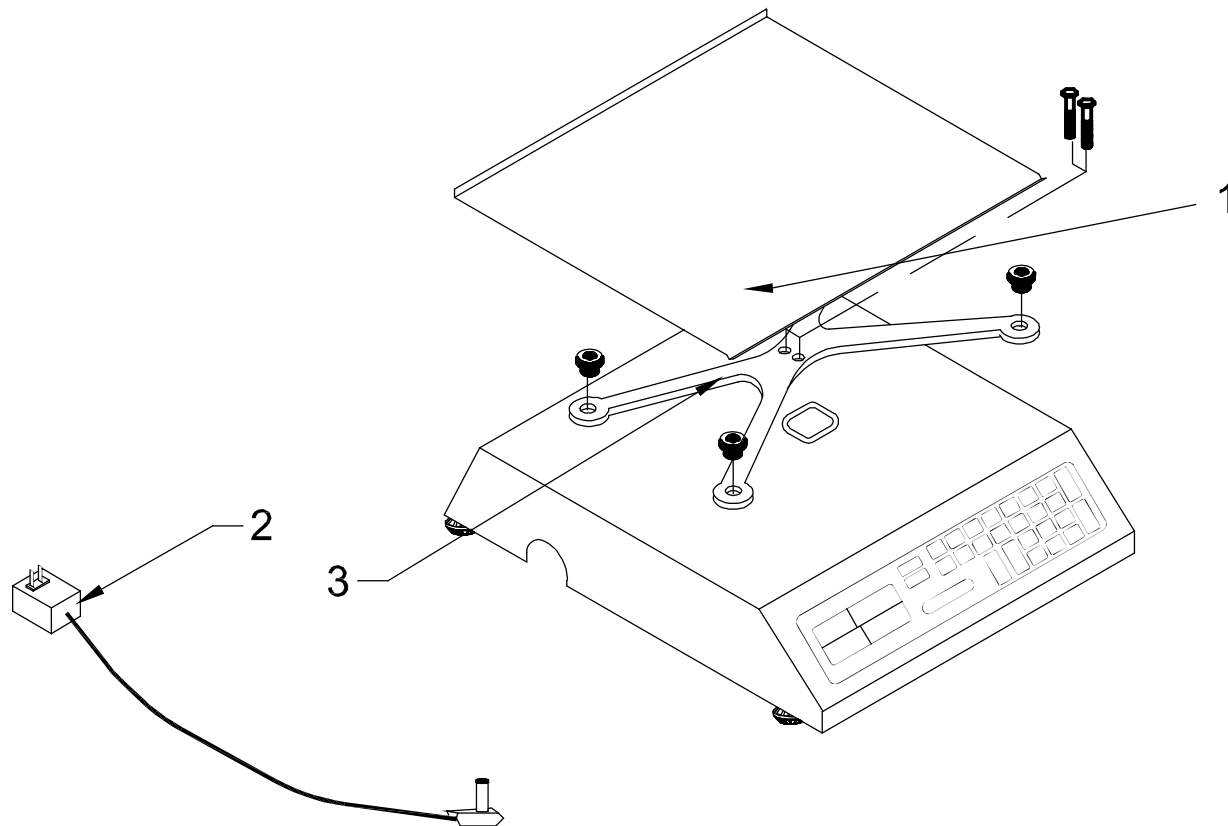



COMERCIAL SCALE

Line: Electronic Scale

Brand: TORREY

Model: PC40LT , PC80LT

Page 1-13

No.	Description	Code
01	PCR-20 PLATE	56300257
02	AC/DC POWER SUPPLY 110/220V 9VCC	21900706
03	MFQ PLATE HOLDER ASSEMBLED	36700067

FROM THE SERIAL NUMBER: G18-000101 (PC40 LT)
G18-000101 (PC80 LT)

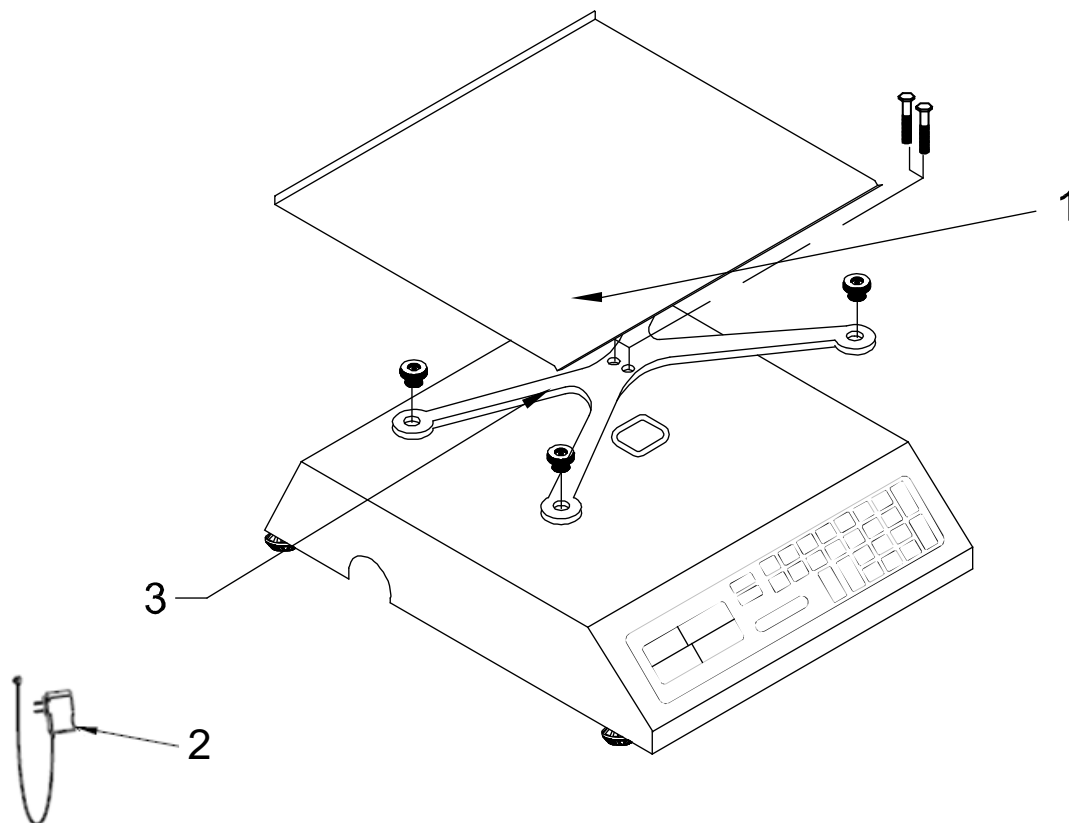



COMERCIAL SCALE

Line: Electronic Scale

Brand: TORREY

Model: PC40LT / PC80LT

Page 1-18

No.	Description	Code
01	PCR-20 PLATE	56300257
02	AC/DC POWER SUPPLY 110/220V 6Vcc	21900978
03	MFQ PLATE HOLDER ASSEMBLED	36700067

COMERCIAL SCALE

Line: Electronic Scale

Brand: TORREY

Model: PC40LT / PC80LT

Page 2-13

FROM THE SERIAL NUMBER: F10-000001 (PC40 LT)
D11-000001 (PC80 LT)

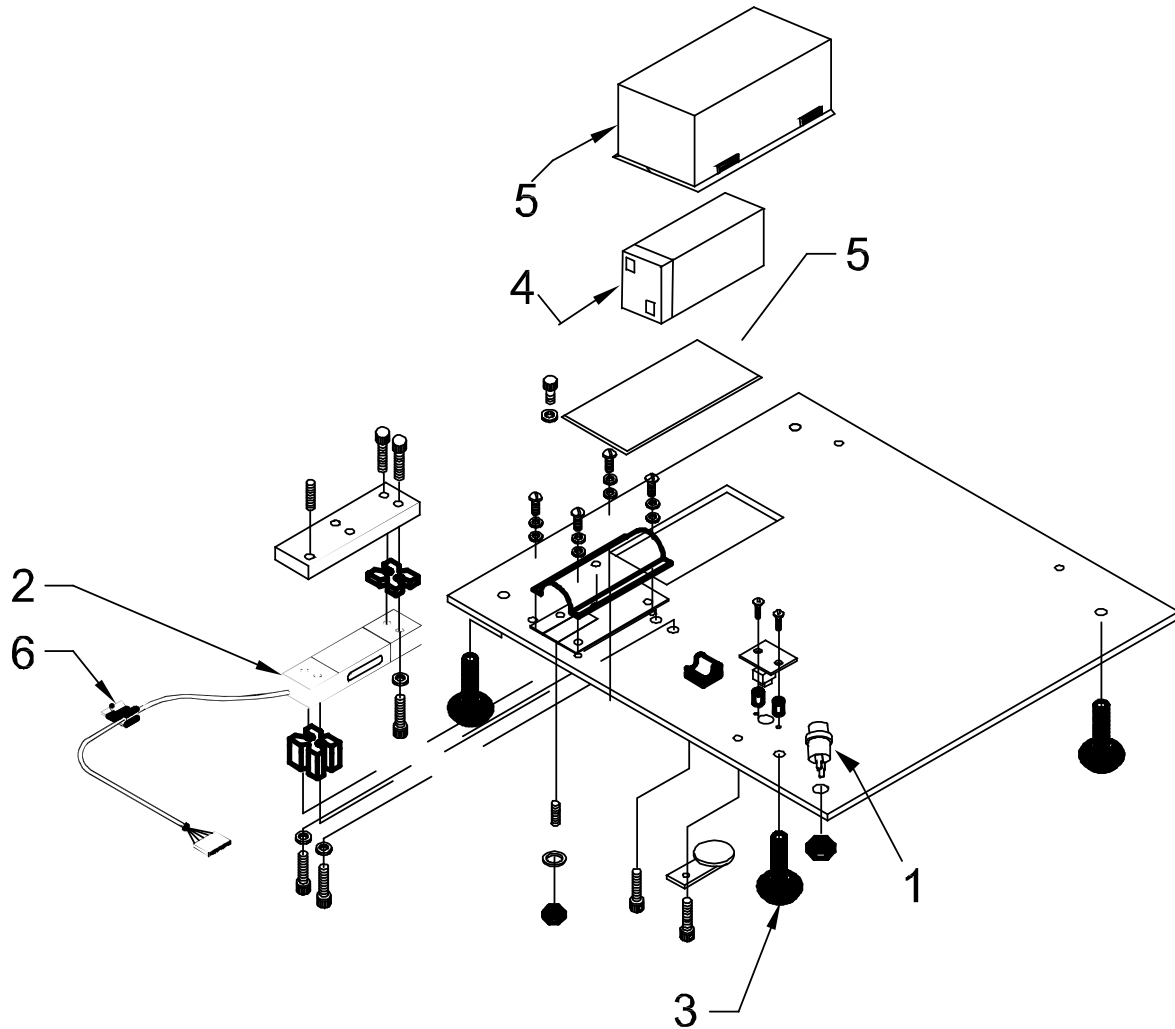

No.	Description	Code
01	38 CM JACK NO POL ASSEMBLED	46600717
02	WEIGHT SENSOR 20 KG M022 USA NO POL ASSEMBLY	46600964
03	CIRCULAR LEVELING BASE PCR	22400041
04	BATTERY 6V 2.5 AH	21900490
05	SNAP BOX KIT	36700349
06	PLAST HOLDER FLAT CABLE	46600720

FOR THE PC80LT MODEL

No.	Description	Code
01	THREADED JACK LPCR40 ASSEMB.	46601093
02	LOAD CELL 40 KG FAIRRITE ASSEMBLED	46600695

COMERCIAL SCALE

Line: Electronic Scale

Brand: TORREY

Model: PC40LT / PC80LT

Page 2-14

FROM THE SERIAL NUMBER: I14-000523 (PC40 LT)
I14-00165 (PC80 LT)

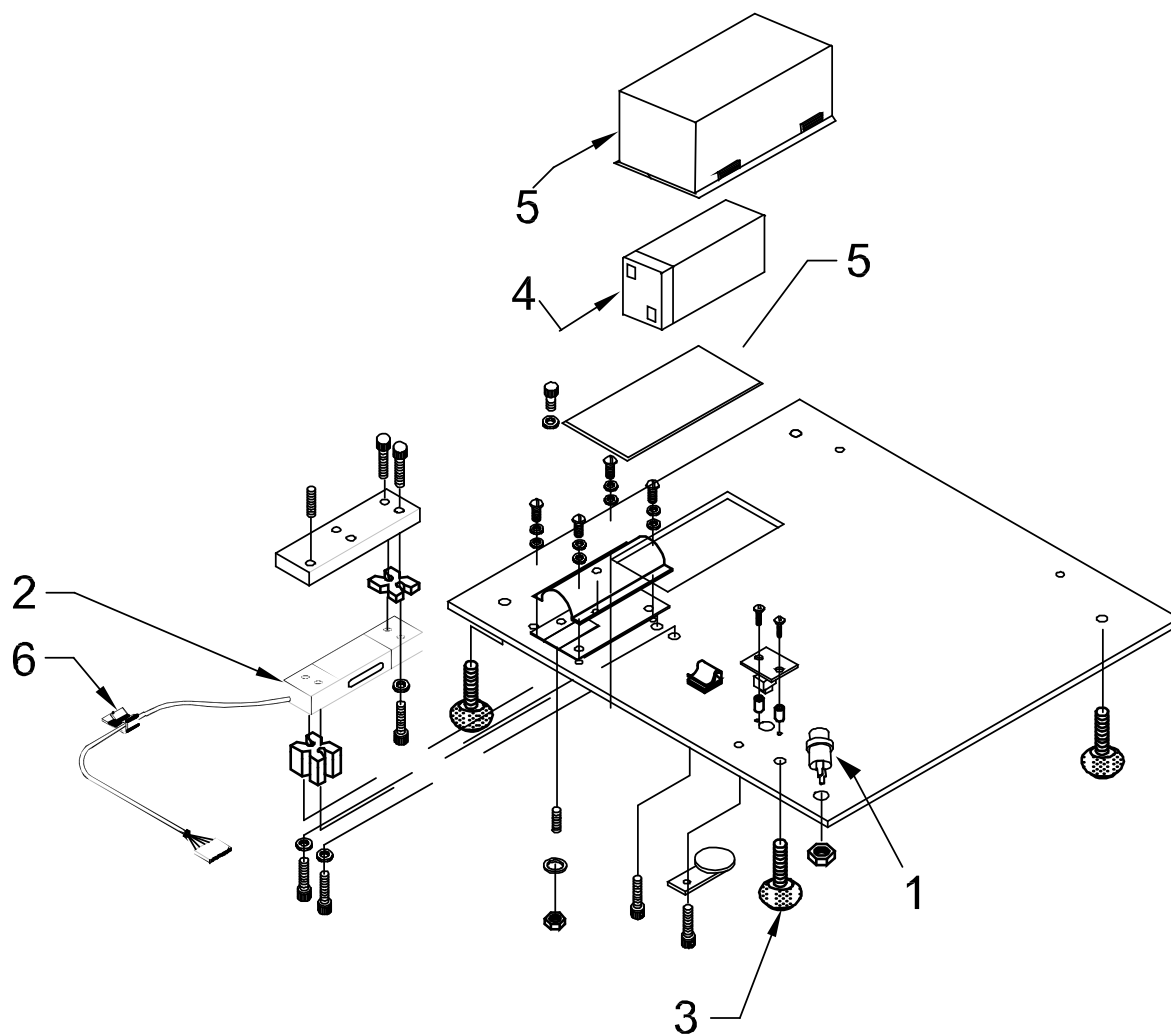

No.	Description	Code
01	38 CM JACK NO POL ASSEMBLED	46600717
02	WEIGHT SENSOR 20 KG M022 USA NO POL ASSEMBLY	46600964
03	CIRCULAR LEVELING BASE PCR	22400041
04	RECHARGEABLE BATTERY 6V, 4.5 AH	21900003
05	SNAP BOX KIT	36700349
06	PLAST HOLDER FLAT CABLE	46600720

FOR THE PC80LT MODEL

No.	Description	Code
01	THREADED JACK LPCR40 ASSEMB.	46601093
02	LOAD CELL 40 KG FAIRRITE ASSEMBLED	46600695

COMERCIAL SCALE

Line: Electronic Scale

Brand: TORREY

Model: PC40LT / PC80LT

Page 2-18

FROM THE SERIAL NUMBER: G18-000101 (PC40 LT)
G18-000101 (PC80 LT)

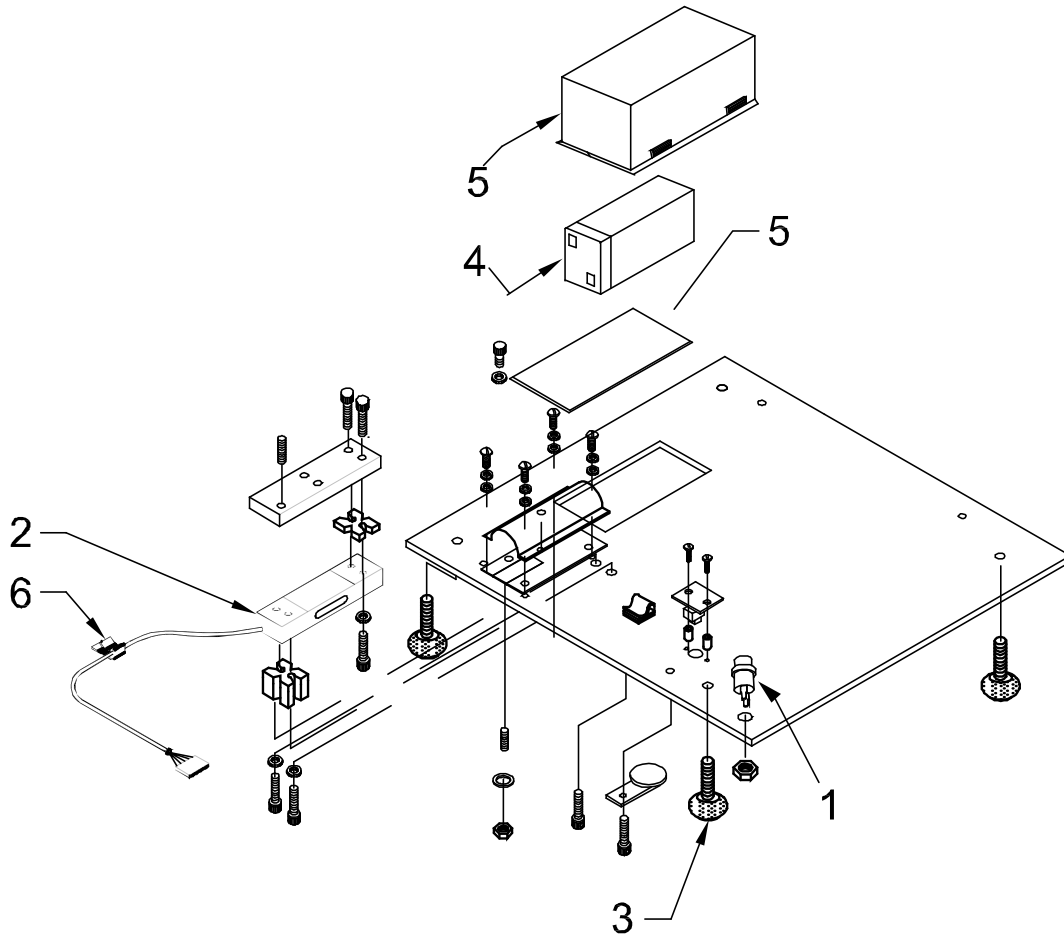

COMERCIAL SCALE

Line: Electronic Scale

Brand: TORREY

Model: PC40LT / PC80LT

Page 2-18

No.	Description	Code
01	38 CM JACK NO POL ASSEMBLED	46600717
02	WEIGHT SENSOR 20 KG M022 USA NO POL ASSEMBLY	46600964
03	CIRCULAR LEVELING BASE PCR	22400041
04	BATTERY 6V 2.5 AH	21900926
05	SNAP BOX KIT	36700349
06	PLAST HOLDER FLAT CABLE	46600720

FOR THE PC80LT MODEL

No.	Description	Code
01	THREADED JACK LPCR40 ASSEMB.	46601093
02	LOAD CELL 40 KG FAIRRITE ASSEMBLED	46600695

COMERCIAL SCALE

Line: Electronic Scale

Brand: TORREY

Model: PC40LT / PC80LT

Page 3-13

FROM THE SERIAL NUMBER: F10-000523 (PC40 LT)
F10-000523 (PC80 LT)

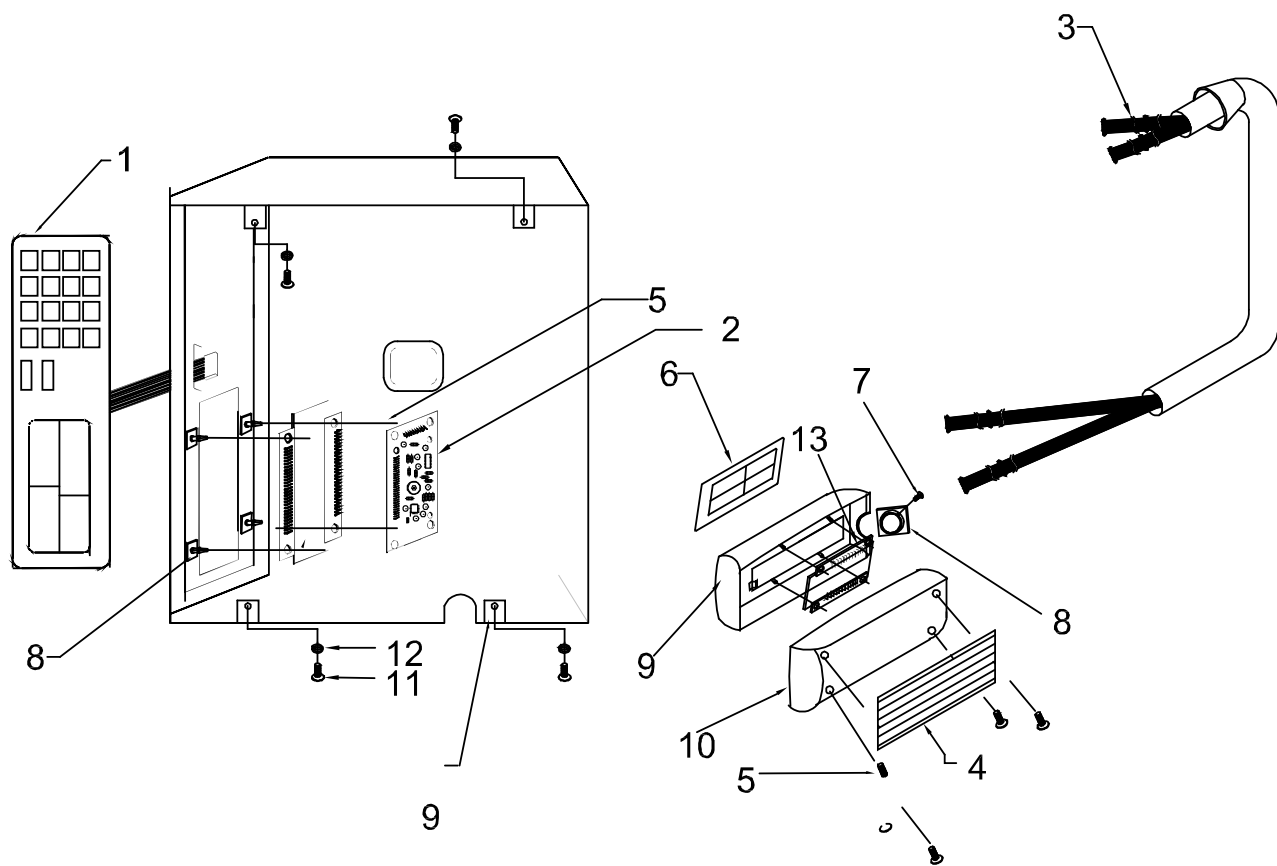



COMERCIAL SCALE

Line: Electronic Scale

Brand: TORREY

Model: PC40LT / PC80LT

Page 3-13

No.	Description	Code
01	MEMBRANE SWITCH PC 0.01 DIV	20200081
02	ASR2 MFQ PC USA MASTER BOARD ASSEM	46600849
03	UP HARNESS FLAT CABLE L-PCR T ASSEMBLY	46600720
04	LIST OF MEMORIES ING- ESP	23300055
05	BOARD HOLDER PINGOOD	12400118
06	OVERLAY PC/MFQ-40LT R.0	23300120
07	1/4-20 X 1/2 SCREW GALV	12100254
08	ALUM. NUT FOR MODULE	56100444
09	FRONT PCR, MFQ TURRET PLASTIC MODULE	22400105
10	POST PCR, MFQ TURRET PLASTIC MODULE	22400106
11	3/16-24X 3/8 SCREW ROUND	12100001
12	3/16 WASHER SPLIT LOCK GALV.	12100020
13	POST TTD WITH BACKLIGHT F-TEC ASSEMBLY	46600777

COMERCIAL SCALE

Line: Electronic Scale

Brand: TORREY

Model: PC40LT / PC80LT

Page 3-14

FROM THE SERIAL NUMBER: J14-XXXXXX (PC40 LT)
J14-XXXXXX (PC80 LT)

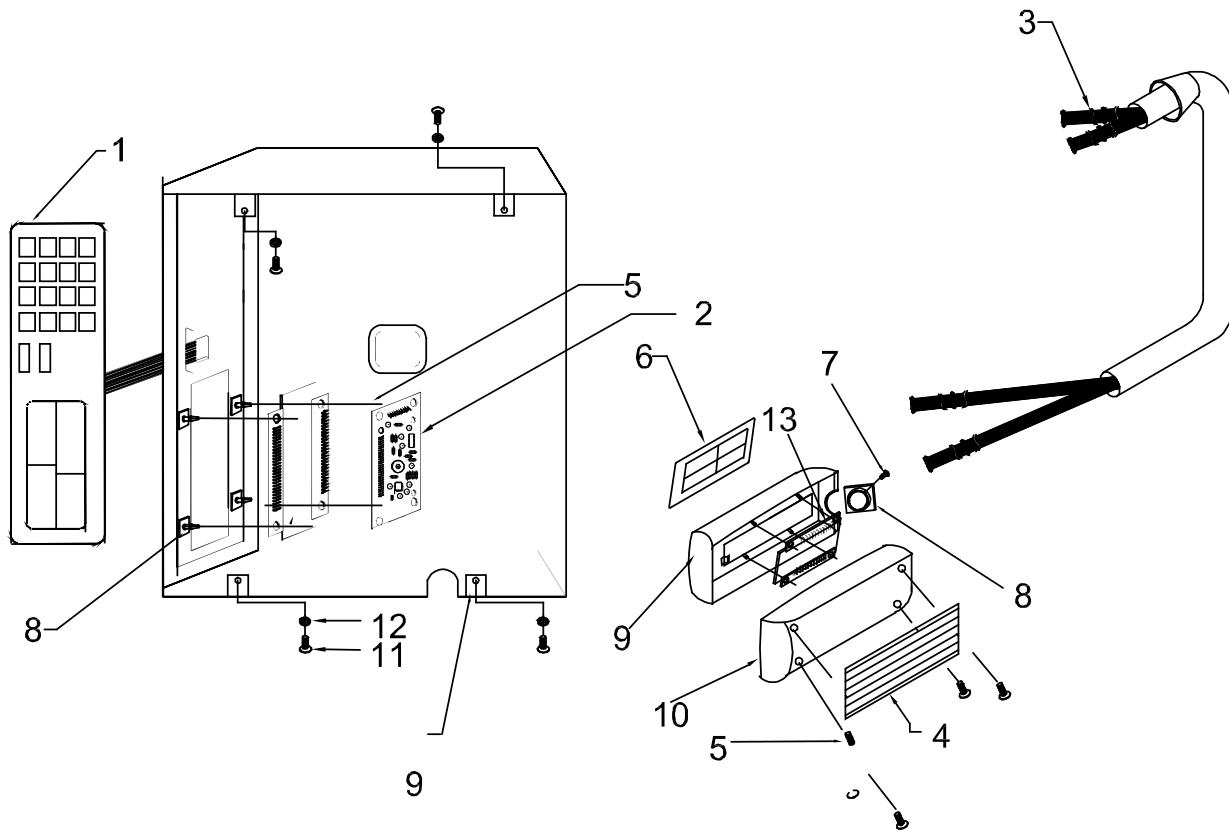



COMERCIAL SCALE

Line: Electronic Scale

Brand: TORREY

Model: PC40LT / PC80LT

Page 3-14

No.	Description	Code
01	MEMBRANE SWITCH PC 0.01 DIV	20200081
02	ASR2 MFQ PC USA MASTER BOARD ASSEM	46600849
03	UP HARNESS FLAT CABLE L-PCR T ASSEMBLY	46600720
04	LIST OF MEMORIES ING- ESP	23300055
05	BOARD HOLDER PINGOOD	12400118
06	OVERLAY PC/MFQ-40LT R.0	23300120
07	1/4-20 X 1/2 SCREW GALV	12100254
08	ALUM. NUT FOR MODULE	56100444
09	FRONT PCR, MFQ TURRET PLASTIC MODULE	22400105
10	POST PCR, MFQ TURRET PLASTIC MODULE	22400106
11	3/16-24X 3/8 SCREW ROUND	12100001
12	3/16 WASHER SPLIT LOCK GALV.	12100020
13	POST TTD WITH BACKLIGHT F-TEC ASSEMBLY	46600777

COMERCIAL SCALE

Line: Electronic Scale

Brand: TORREY

Model: PC40LT / PC80LT

Page 3-18

FROM THE SERIAL NUMBER: G18-000101 (PC40 LT)
F18-000101 (PC80 LT)

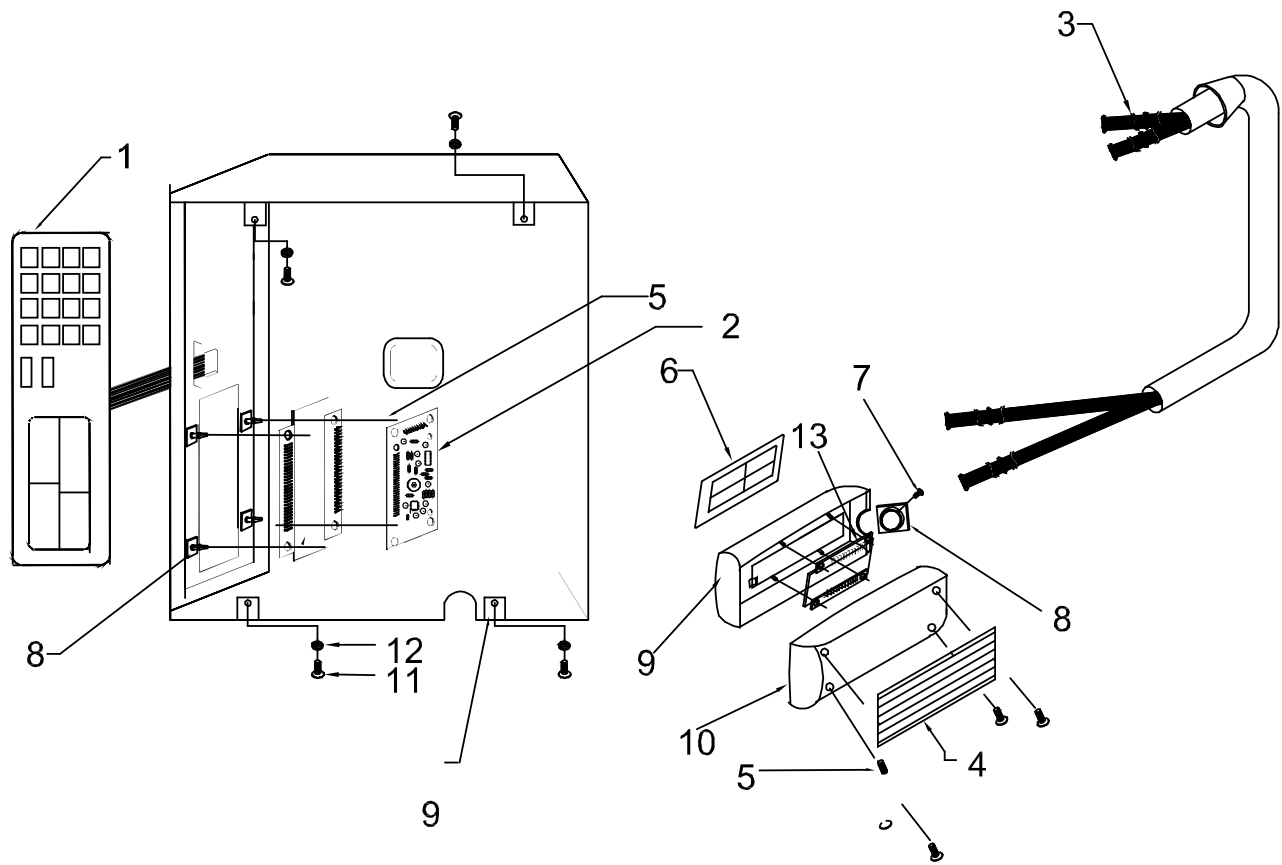

No.	Description	Code
01	TECLADO PC 0.01 DIV NL R0	20200582
02	TMMPTSER (MFQ/PC USA) MASTER BOARD ASSEM.	46601337
03	UP HARNESS FLAT CABLE L-PCR T ASSEMBLY	46600720
04	LIST OF MEMORIES ING- ESP	23300055
05	BOARD HOLDER PINGOOD	12400118
06	OVERLAY PC/MFQ40LT R.0 (95041A9) NL R0	23300552
07	1/4-20 X 1/2 SCREW GALV	12100254
08	ALUM. NUT FOR MODULE	56100444
09	FRONT PCR, MFQ TURRET PLASTIC MODULE	22400105
10	POST PCR, MFQ TURRET PLASTIC MODULE	22400106
11	3/16-24X 3/8 SCREW ROUND	12100001
12	3/16 WASHER SPLIT LOCK GALV.	12100020
13	POST TTD WITH BACKLIGHT F-TEC ASSEMBLY	46600777

FOR THE PC80LT MODEL

No.	Description	Code
01	TECLADO PC80L NL R0	20200583
02	TURRET OVERLAY (CALCOM) MFQ/PC-80L NL R0	23300543