

# RECEIVING SCALE

Line: Electronic Scale

Brand: TORREY

Model: EQB50/100-W , EQB100/200-W

Page 1-12

FROM THE SERIAL NUMBER: J11-000193

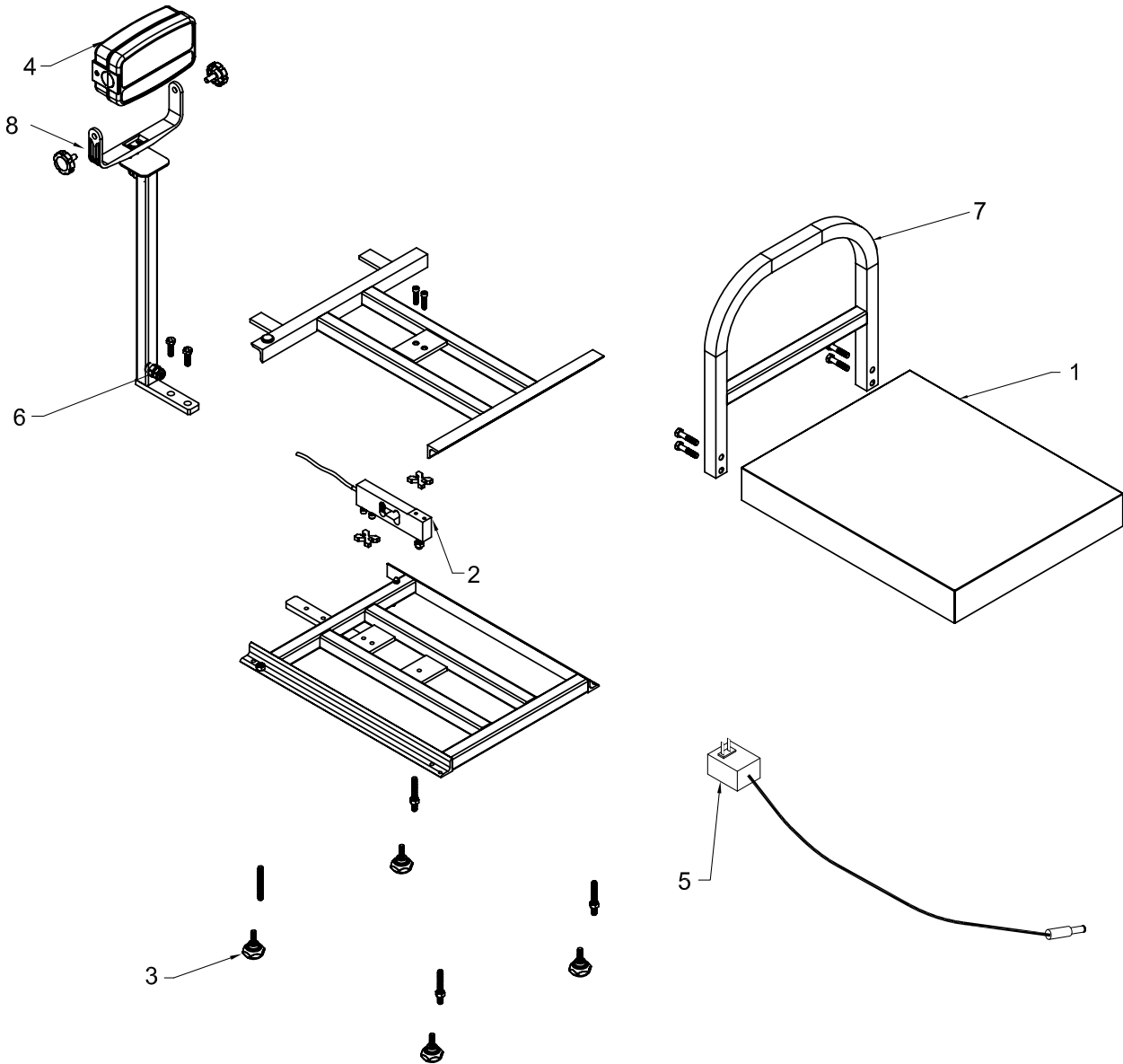



## RECEIVING SCALE

Line: Electronic Scale

Brand: TORREY

Model: EQB50/100-W , EQB100/200-W

Page 1-12

No.	Description.	Code
01	PLATE EQB-50/100	B-36400012
02	50 KG MOD M1140 LOAD CELL ASSEMBLED	B-20100015
03	NIVELATION FEET EQB-W	B-12400092
04	WI-W MODULE ENS.	SEE PAG. 02
05	AC/DC POWER SUPPLY 110/220 VCA 9Vcc 500 mA	B-21900706
06	CONECTOR LIQUIT TIGHT 3/8	B-21900107
07	BPOLISHED BACKING EQB50/100 W	B-36400014
08	MODULE SUJ. BLACK #P29F516S050	B-11900144

FOR MODEL EQB100-W

No.	Description.	Code
02	100 KG MOD M1140 LOAD CELL ASSEMBLED	B-20100134

# RECEIVING SCALE

Line: Electronic Scale

Brand: TORREY

Model: EQB50/100-W , EQB100/200-W

Page 2-12

FROM THE SERIAL NUMBER: L12-000192 (EQB-50)  
A13-000665(EQB-100)

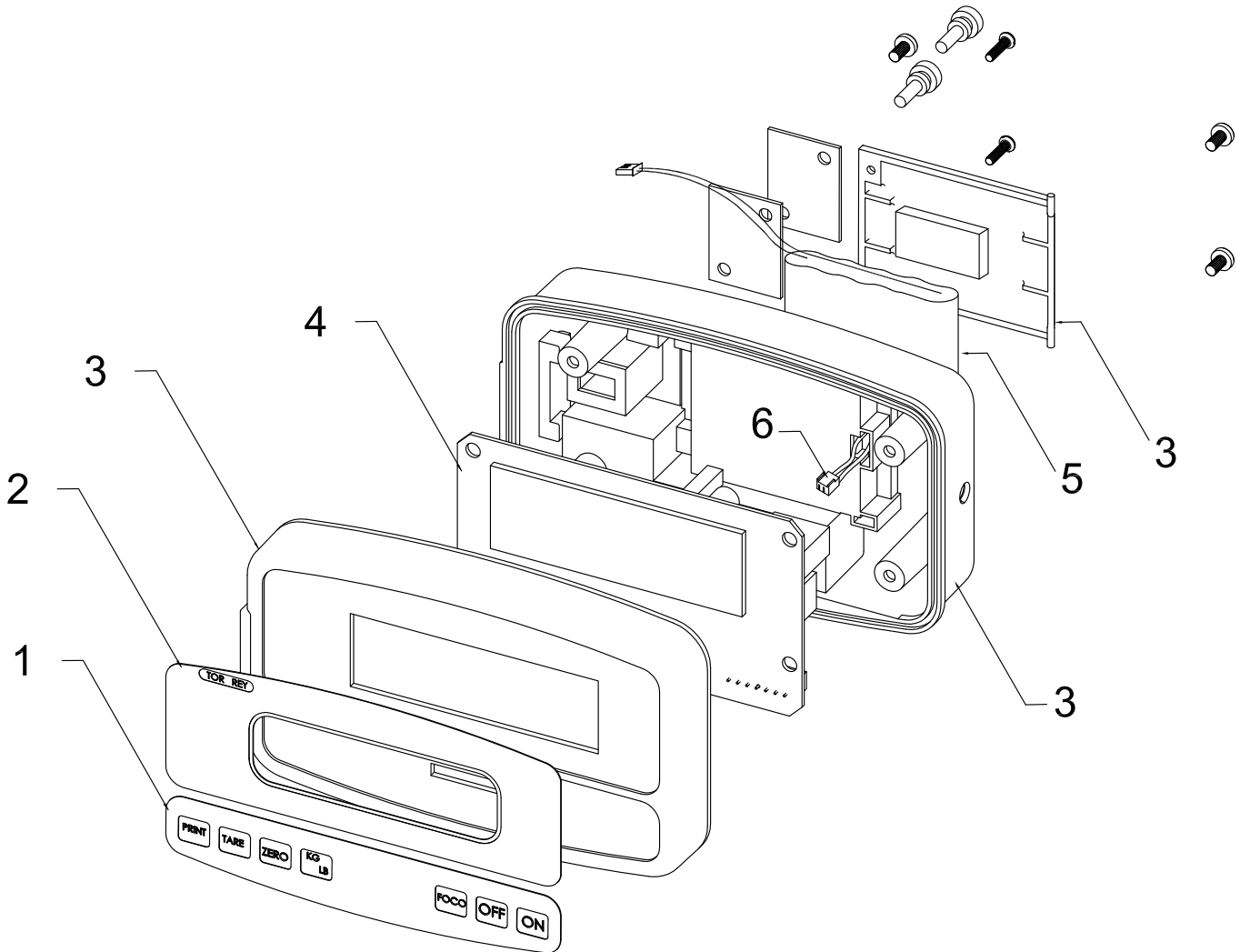



## RECEIVING SCALE

Line: Electronic Scale

Brand: TORREY

Model: EQB50/100-W , EQB100/200-W

Page 2-12

No.	Description.	Code
01	KEYBOARD MODULE WI 3D WP	B-20200523
02	OVERLAY EQB50/100 W	B-23300114
03	KIT MODULE WI (CASE)	B-36700345
04	MASTER BOARD TMWISTRØ MODS W ENS.	B-46601112
05	6V BATTERY 900 [mah] NiMH	B-21900751
06	BATTERY ARNESS WI MH ENS	B-46601073

FOR MODEL EQB100-W

No.	Description.	Code
02	OVERLAY EQB100/200 W	B-23300115

# RECEIVING SCALE

Line: Electronic Scale

Brand: TORREY

Model: EQB50/100-W , EQB100/200-W

Page 2-18

FROM THE SERIAL NUMBER: H18-000XXX (EQB-50)  
H18-000XXX (EQB-100)

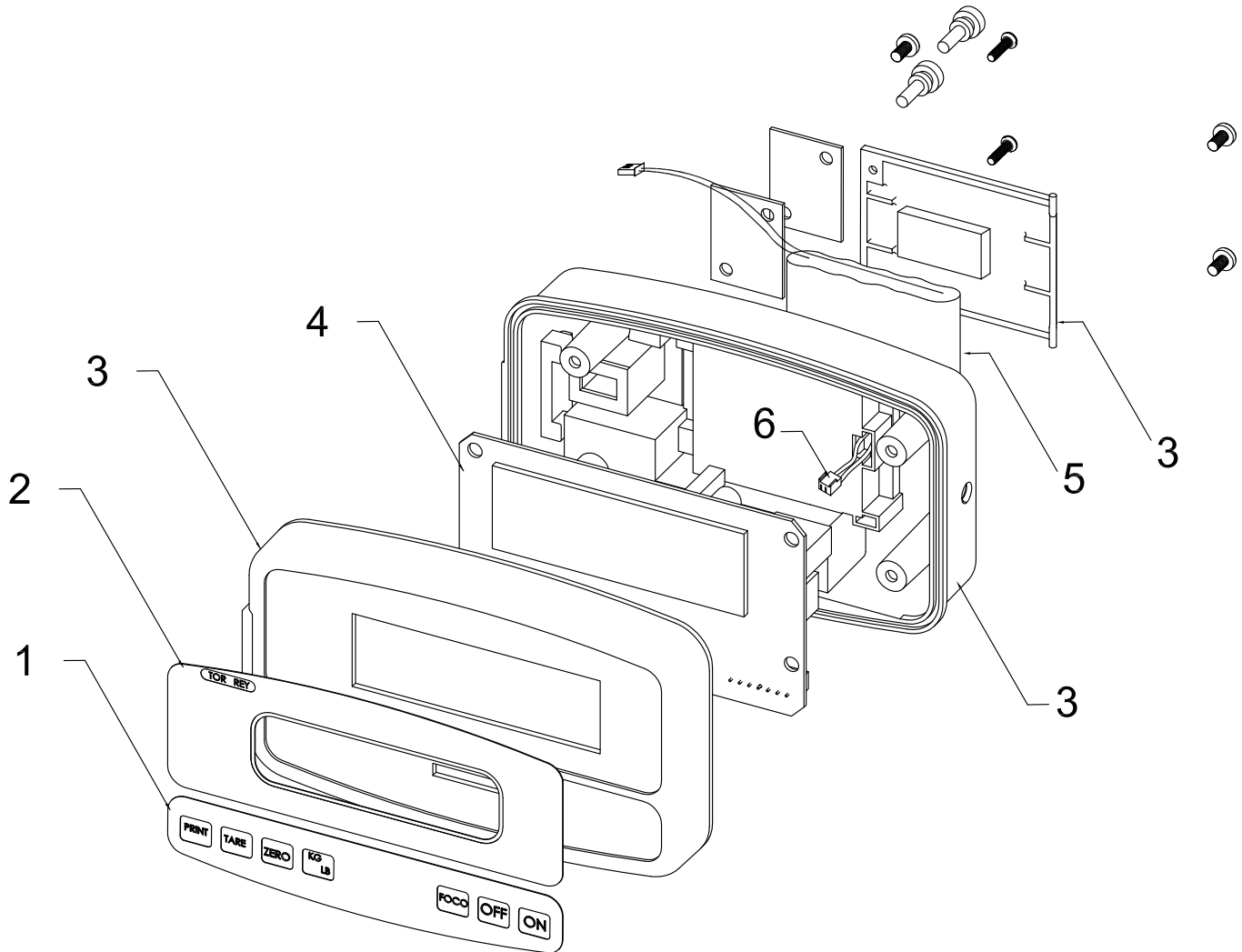



## RECEIVING SCALE

Line: Electronic Scale

Brand: TORREY

Model: EQB50/100-W , EQB100/200-W

Page 2-18

No.	Description.	Code
01	KEYBOARD MODULE WI 3D WP	B-20200523
02	OVERLAY EQB50/100 W USA NTEP	B-23300151
03	KIT MODULE WI (CASE)	B-36700345
04	MASTER BOARD TMWISTR5 W ENS	B-46601377
05	6V BATTERY 900 [mah] NiMH	B-21900751
06	BATTERY ARNESS WI MH ENS	B-46601073

FOR MODEL EQB100-W

No.	Description.	Code
02	OVERLAY EQB100/200 W	B-23300115