



LABELING / PRINTING SCALES

WLS SERIES

Model:
WLS-40L



Product features

- ✓ Available in 40 lb capacity
- ✓ Add your own logo
- ✓ Touch screen color
- ✓ Measure your employee's performance
- ✓ Wifi connection
- ✓ Stainless steel construction
- ✓ Attend Faster and Earn More Customers
- ✓ Adjustable leveling feet
- ✓ Easy to clean
- ✓ Programmable PLU shortcuts for faster operation

Product highlights



Tablet and PC connection



Thermal printer , tickets and tags



Free "scalelink" APP available

Certifications



Warranty





LABELING / PRINTING SCALES

WLS SERIES

Dimensions

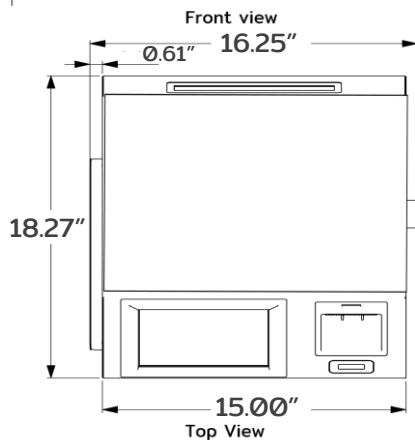
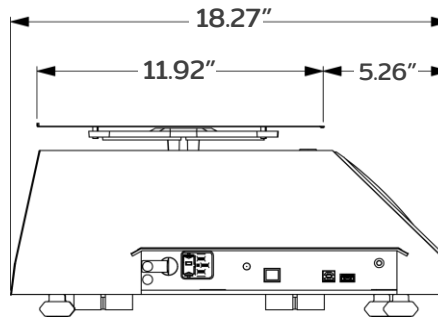
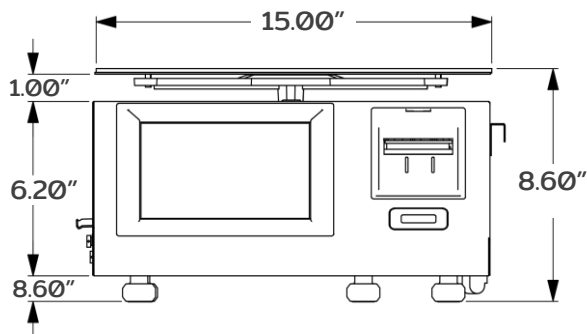

Technical specifications

Dimensions

External dimensions	W: 18.27" D:15.00" H: 8.60"
Packing dimensions	W: 20.07" D:25.98" H: 14.76 "
Net weight	35.05 Lbs.
Total weight (packing included)	36.59 Lbs.
Plate dimensions	W: 11.92" D: 15.00" H: 0.5"

Construction

Cabinet material	Food grade stainless steel
Plate material	Food grade stainless steel
Plate holder	High strength reinforced plastic
Leveling feet	4

Logistic data

Units per pallet	5
Weight per pallet	771.61 lb
Dim. Per pallet	44.881" x 51.968" x 78.740"
Storage temperature	-4°F to 122°F (-20°C to 50°C)

Electrical data

Power supply	100-240 Vca / 47/63 Hz
Ampers	1.2A/220V 2.4A/115V
Cord length	70.86"
Lighting	LED
Plug type	NEMA-5-15P
Display	Thin-Film-Transistor (TFT Display)

Performance data

Capacity	40 lb
Minimal division	0.01 lb
Max. Tare	40 lb

Additional data

Communication	USB, ETHERNET, WIFI
App available on Android and iOS	App "scalelink" software
Software PC available	Software Admin scale WLS
Operation temperature	14°F to 104°F (-10°C to 40°C)