



PORTIONING SCALE

PZC SERIES

Model:

PZC-5 / 10

PZC-10 / 20



Product features

- ✓ Available in 10 or 20 lb capacities
- ✓ Stainless Steel case and plate
- ✓ Large LCD display with backlight
- ✓ Toggles between kilograms and pounds
- ✓ 100 hours duration rechargeable battery
- ✓ Tare function
- ✓ Pedal foot for tare operation (optional)

Product highlights



LCD display and backlight



Pedal foot for handsless operation



Adjustable display

Certifications



Warranty





PORTIONING SCALE

PZC SERIES

Dimensions

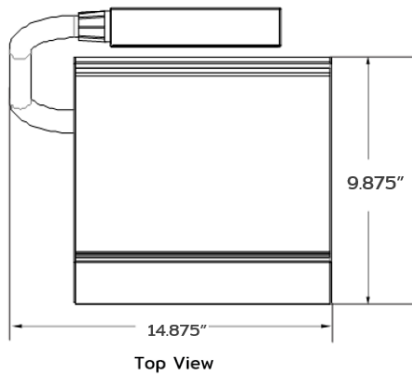
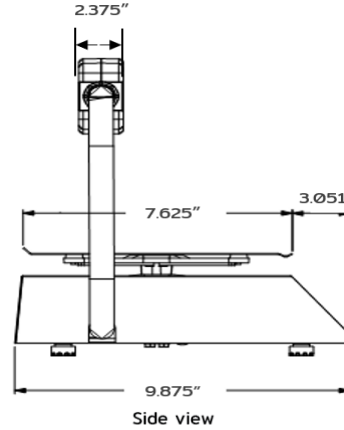
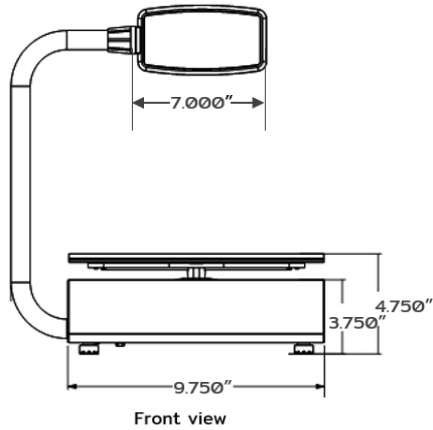

Technical specifications

Dimensions PZC-5/10 PZC-10/20

External dimensions	W: 14.29 " D:14.05 " H: 5.47 "
Packging dimensions	W: 17.32 " D:17.32 " H: 8.66"
Net weight	10.9 lb
Total weight (packing included)	15.4 lb
Plate dimensions	W: 7.80 " D: 9.60" H: 1.00 "

Construction

Cabinet material	Stainless steel
Plate material	Stainless steel
Plate holder	High strength reinforced aluminium
Leveling feet	4 adjustable foot

Logistic data

Units per pallet	40
Weight per pallet	616.00 lb
Dim. Per pallet	44.88" x 51.96" x 78.740"
Storage temperature	-4°F to 122°F (-20°C to 50°C)

Electrical data

Power supply	100-240 Vca / 47/63 Hz
Ampers	0.2 A
Cord length	70.86"
Lighting	LED
Plug type	NEMA-5-15P
Display	LCD display with backlight

Performance data

Capacity	10.00 lb & 20.00 lb
Minimal division	0.02 lb & 0.05 lb
Max. Tare	10.00 lb & 20.00 lb

Additional data

Operation temperature	14°F to 104°F (-10°C to 40°C)
Communication	Serial RS-232
Software PC available	Software scale