



SHIPPING / RECEIVING SCALE EQB-W SERIES

Model:
EQB-20/40-W



Available capacity: 40 lb

Product features

- ✓ LED display with backlight
- ✓ Heavy duty platform
- ✓ Robust stainless steel construction
- ✓ Hermetically sealed display
- ✓ Toggles between kilograms and pounds
- ✓ Tare function
- ✓ RS 232 serial communication

Technical specifications

Capacity	40 lb (20 kg)
Minimal division	0.01 lb / 0.005 kg
Minimum weighting	0.2 lb / 0.1 kg
Input voltage power adapter	100 to 240 Vac 50/60 Hz
Output voltage	9v 500 mA
Max. Tare	40 lb / 20 kg
Plate dimensions	12 x 15 x 2 ½ in
Operation temperature	14 to 104 °F (-10 to 40 °C)
Storage temperature	-4 to 122 °F (-20 to 50 °C)
Net weight	22.02 lb (10 kg)
Total weight (package included)	26.43 lb (12 kg)

Product highlights



Electronic scale 100 % accurate



Practical and portable



Large solid plate



SHIPPING / RECEIVING SCALE EQB-W SERIES

Dimensions:

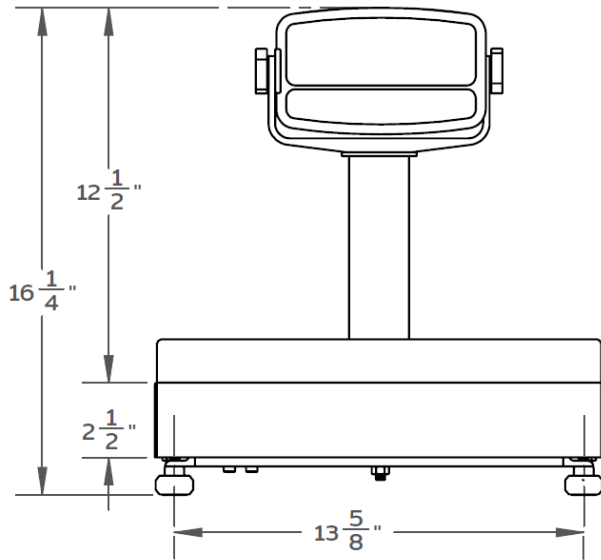

Front view

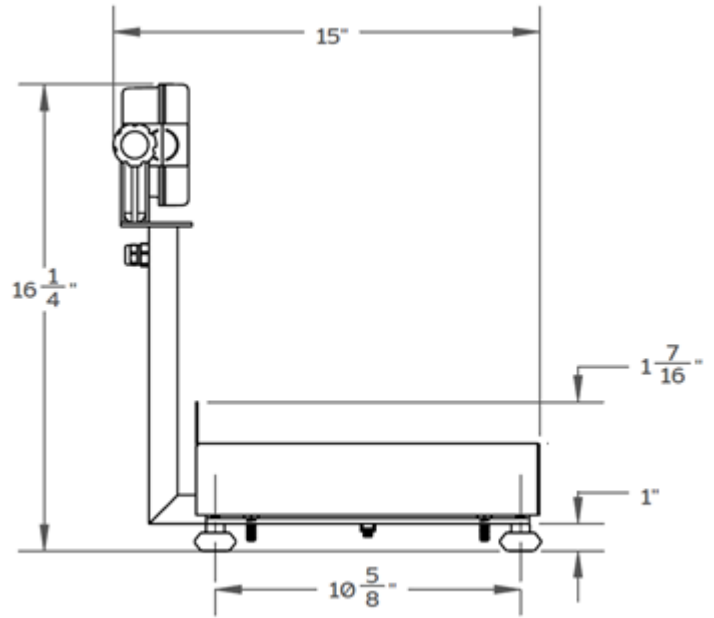

Side view

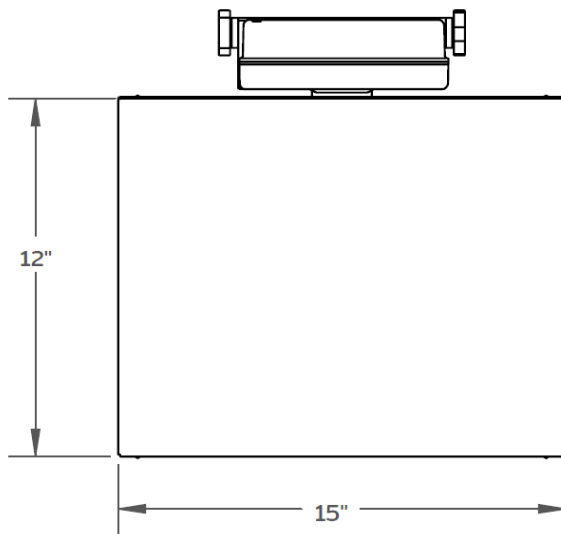

Top view

Product attributes

- Stainless Steel construction
- Easy and rapid assembly
- Long battery life
- Adjustable leveling feet
- Waterproof structure

Certifications



Warranty





SHIPPING / RECEIVING SCALE

EQB-W SERIES

Model:
EQB-50/100-W
EQB-100/200-W



Available capacities: 100 lb and 200 lb

Product features

- ✓ LED display with backlight
- ✓ Heavy duty platform
- ✓ Robust stainless steel construction
- ✓ Hermetically sealed display
- ✓ Toggles between kilograms and pounds
- ✓ Tare function
- ✓ RS 232 serial communication

Technical specifications

Capacities	100 lb / 50 kg 200 lb / 100 kg
Minimal division	0.01 kg / 0.02 lb 0.02 kg / 0.05 lb
Power adapter	9v 500 mA included
Input voltage	100 to 240Vac, 50/60Hz
Max. Tare	25 Kg / 50 lb
Plate dimensions	19 x 15 x 2 ¾ in
Operation temperature	14 to 104 °F (-10 to 40 °C)
Storage temperature	-4 to 122 °F (-20 to 50 °C)
Net weight	39.6 lb
Total weight (package included)	43.2 lb

Product highlights



Electronic scale 100 % accurate



Practical and portable



Large solid platform



SHIPPING / RECEIVING SCALE EQB-W SERIES

Dimensions:

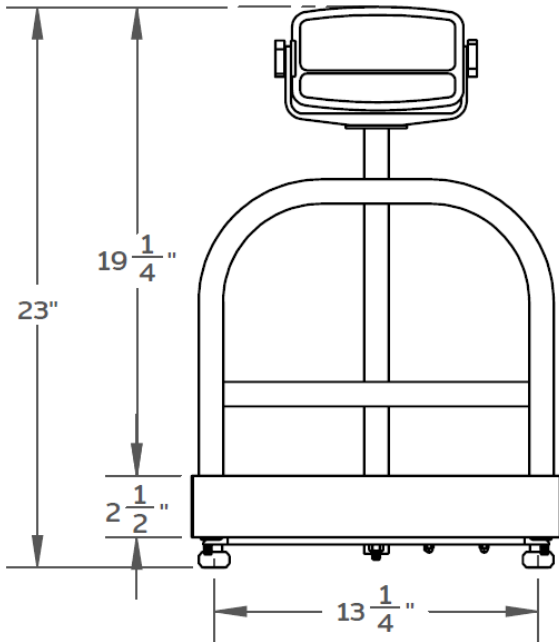

Front view

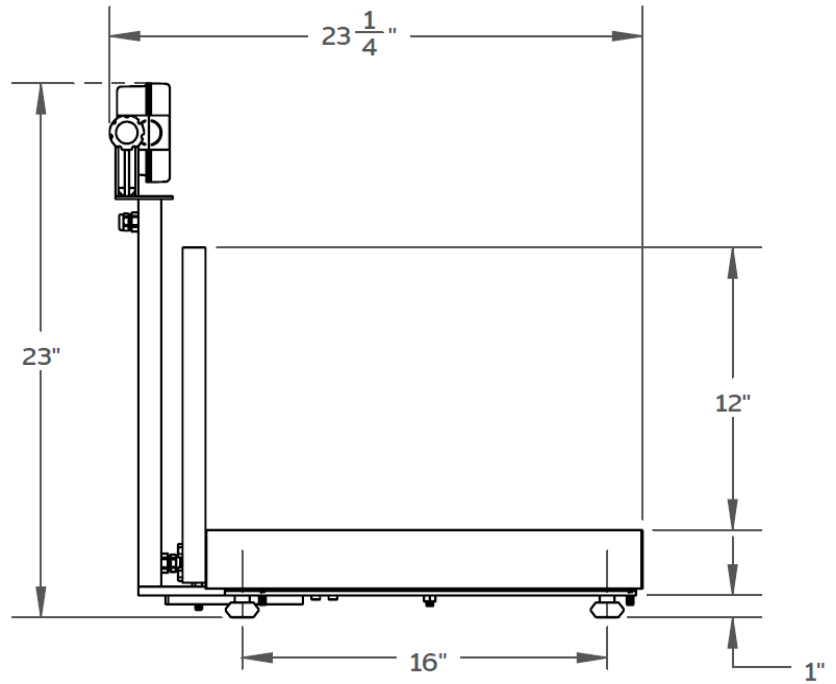

Side view

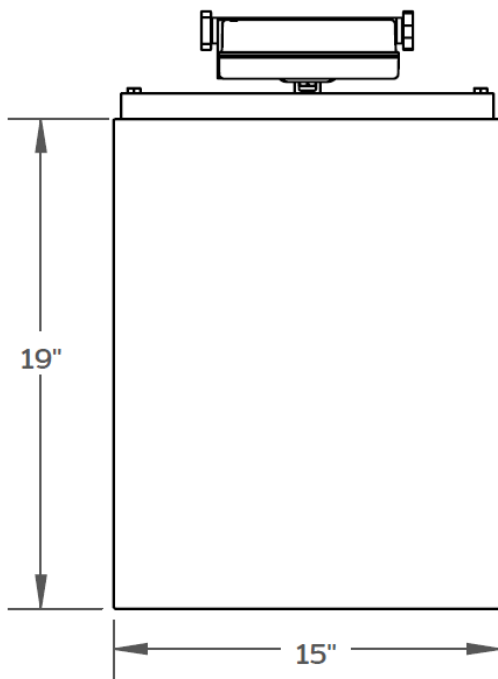

Top view

Product attributes

- Stainless Steel construction
- Easy and rapid assembly
- Long battery life
- Adjustable leveling feet
- Waterproof structure

Certifications



Warranty





RECEIVING SCALES EQB-W SERIES

Model:
EQB TABLE



Available models: EQB50/100-W EQB50/100-W

Product features

- ✓ Available for different models
- ✓ Built to last
- ✓ Robust carbon steel table with lead free epoxy finish

Technical specifications

Dimensions 28.625 x 15.25 x 18.875 in

Product highlights



Easy to assemble



Practical and portable

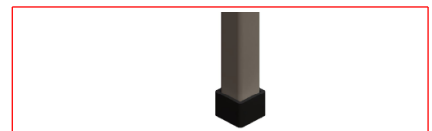

Anti-slip feet



RECEIVING SCALES EQB-W SERIES

Dimensions:

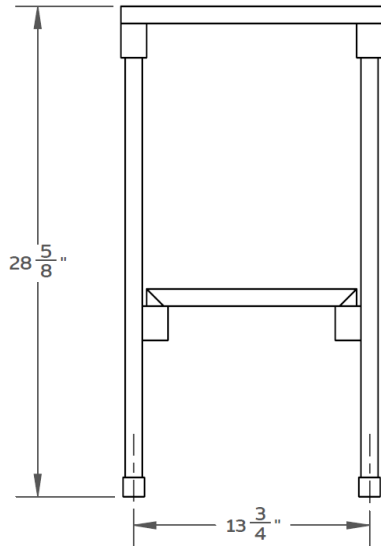

Front view

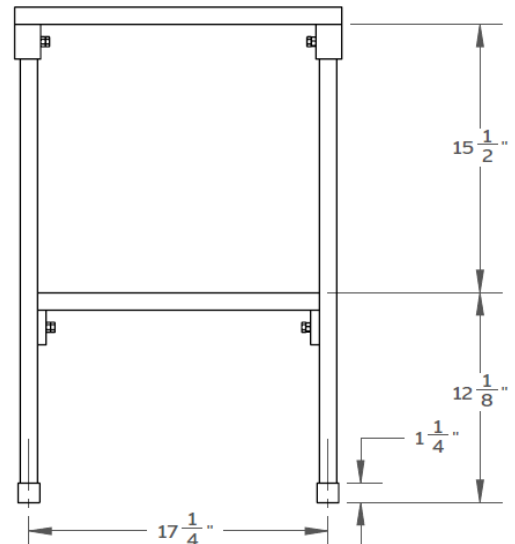

Side view

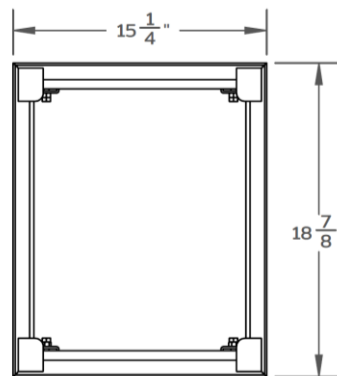

Top View

Product attributes

Gray Color

Carbon Steel construction

Easy and rapid installation

Certifications



Warranty

